

KRESS

200C COAL HAULER Series II



Cat 3512B HD Electronic Unit Injection Engine

Gross power at 1750 rpm 1268kW 1700hp

Flywheel power at 1750 rpm 1197kW 1605hp

Body Capacity (SAE 3:1) 228m³ 298 yd³

Payload Weight

Standard Configuration 220 metric tons 240 tons

200C II Coal Hauler

Engineered for performance, designed for comfort, built to last.

Mechanical Power Train

Starting with the high torque rise, Caterpillar® 3512B HD, Electronic Unit Injection (EUI) diesel engine, through the electronic, six speed power shift transmission, the mechanical power train is designed and built by Caterpillar and Kress, assuring the highest standards for quality, performance, efficiency and reduced operating costs.

pg.4-5

Engine Power Train Integration

The Caterpillar intelligent power train combines engine, transmission and brake information over the CAT Data Link to optimize overall truck performance. The CAT Data Link allows the engine and transmission to electronically exchange information so the components work together as a system to allow for smooth shifting which will increase component life and improve operator comfort. The Electronic Technician (ET) software program can access stored diagnostic data to reduce downtime and improve troubleshooting.

pg. 6-7

Oil cooled Rear Disc Brakes

Caterpillar rear wheel oil-cooled, multiple disc brakes are continuously cooled for exceptional, non fade braking and retarding. The Integrated Braking Control (IBC) system integrates the Automatic Retarder Control (ARC) on rear wheels to enhance truck performance and productivity.

pg. 8



Top performance.

The 200C II is designed for high production and low cost per ton hauling in mining applications.

Reliable, durable operation.

Field proven, unitized construction and easy maintenance guarantee extended life with low operating costs.

Operator's Station

The 200C II operator's station has been significantly improved over previous models by ergonomically designing for total machine control in a quiet comfortable, and productive environment. All controls, levers, switches, and gauges are positioned to maximize productivity and minimize operator fatigue. The ROPS structure, effectively inside the rollover envelope of the body, provides superior operator protection.

pg. 10

Body Structures

The Kress unitized body is supported on four ultra-soft struts located inside all four corners of the body. This is the ideal location for supporting the body; these two features minimize and balance the stresses throughout the body, reduce body weight, and increase body life.

The unique body design ensures strategic placement of welds in low stress areas, which minimizes fatigue related failures. In areas of higher stress concentrations, generous radii on plate bends are used to dissipate the stresses that can cause fatigue cracking.

Guaranteed high impact resistance, low corrosion, and high wear resistance are all inherent properties of the material used, which results in a lighter, stronger product. This excellent weight savings naturally means economic gains are achieved without sacrificing strength, durability, or life.

pg.12

**Vehicle Suspension fully compensated/
Dual chambered.**

600 mm (24") of stroke in each suspension cylinder with dual nitrogen charged chambers provide an ultra smooth ride in either the loaded or empty condition. **pg.12**

Vital Information Management System (VIMS)

Vital Information Management System (VIMS) monitors vital machine systems and functions. It helps coach the operator in the operation of the machine and alerts him to "out of specification conditions". Down time and repair costs are reduced by allowing for early detection of problems and allowing service personnel to access machine data for faster, more accurate diagnosis. VIMS provides information to enhance equipment management, increase productivity, and reduce cost-per-ton.

pg. 14-15



Engine

The field proven 3512B HD EUI engine delivers the power and reliability necessary to perform in the world's most demanding mining applications.

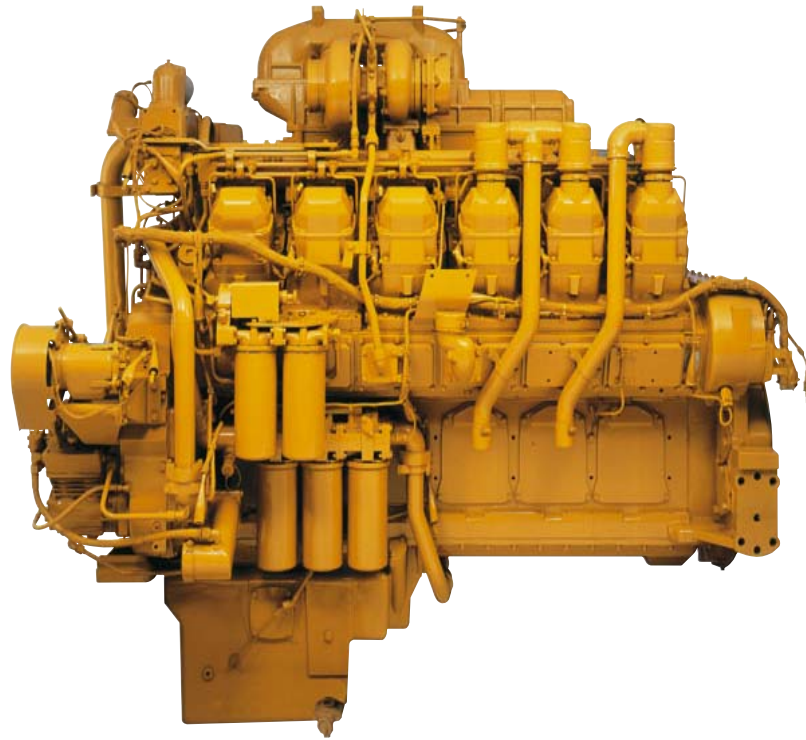

The Caterpillar Electronic Unit Injector (EUI) diesel engine is a four stroke design that uses long, effective power strokes for more complete fuel combustion and optimum efficiency. The 3512B HD is designed with high displacement and a low operating rpm rating for extended hours of service between scheduled overhauls and reduced operating costs.

- **The 19 percent torque rise** provides high lugging force during acceleration and less down shifting on grade or in rough underfooting for faster cycle times. Torque rise effectively matches the transmission shift points to maximize efficiency and yield higher performance.

The 3512B HD EUI engine provides unmatched combustion efficiency:

- **Electronic Unit Injector (EUI)** is a proven high pressure, direct injection fuel system. New components of the fuel system provide 22 percent higher injection pressures than the previous generation of 3500 engines. The higher pressures provide improved response times and more efficient fuel burn with lower emissions and less smoke.

- **Electronic Control Module (ECM)** utilizes advanced engine management software to monitor, control and protect the engine utilizing self-diagnosing electronic sensors. The module controls a wide spectrum of engine functions, providing infinitely variable injection timing to maintain peak performance.
- **Two piece articulated pistons** utilize a deep bowl, low crevice volume design that enhances combustion efficiency, improves fuel efficiency and lowers emissions.
- **Separate circuit aftercooler** allows the after cooler coolant to operate at lower temperatures than jacket water for a denser air charge in the combustion chamber.

Results:

- 3512B HD EUI has improved fuel efficiency by five percent; NOx levels are reduced as well as transient smoke levels are down. No derating up to 3048m (10,000ft).

Proven reliability, durability and enhanced serviceability:

- 500 hour service interval for engine oil, oil and fuel filter changes, increasing mechanical availability and production.
- Additional electronic protection of the engine during cold starts, high altitude operations, air filter plugging and high exhaust temperature conditions.
- Quick diagnosis of engine conditions enable effective maintenance and repairs utilizing the Electronic Technician (ET) service tool.

Mechanical Power Train

Completely designed and manufactured by Kress and Caterpillar to assure maximum efficiency, high quality, extended service life and low operating costs.

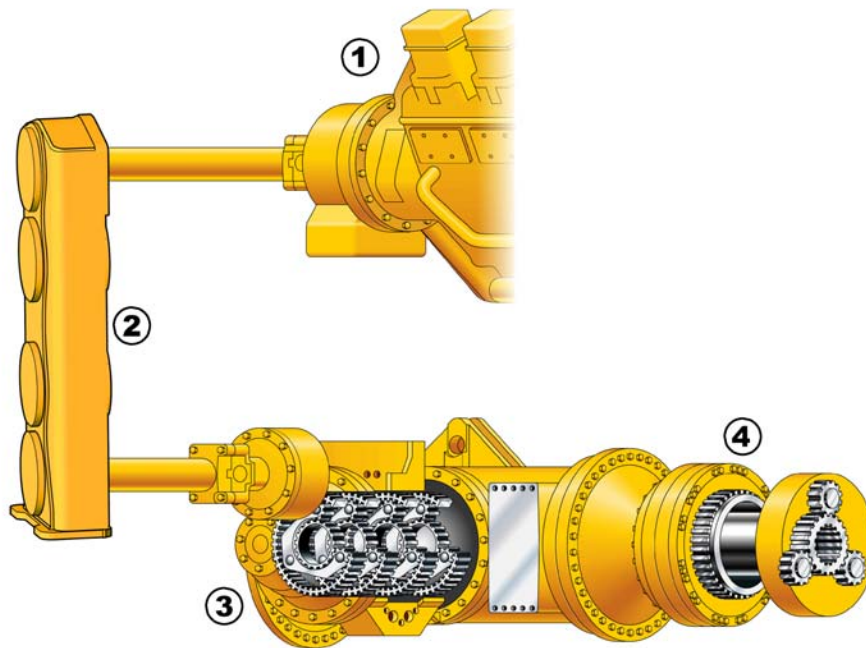

The Kress/CAT mechanical power train is designed for optimum component match. A wide application range is available in each gear. A 35 percent step between each gear allows the transmission to utilize the full torque range of the 3512B HD engine, resulting in fewer shifts for extended power train life.

- Higher power train efficiency provides faster truck speeds with less fuel consumption.

Transmission/Chassis Control (TCC) module communicates over the CAT Data Link with the engine ECM to manage engine speed during shifts for increased clutch life and operator comfort. When the transmission is in sixth gear, the truck can achieve speeds up to 71 km/h (44 mph). The shift points are set at the factory for optimal performance, efficiency and component life.

TCC monitors and records key operating conditions and parameters for later downloading and diagnostic troubleshooting by service personnel.

1 Lock-up Torque Converter combines the maximum rimpull and cushioned shifting of torque converter drive with the efficiency and performance of direct drive. The lock up clutch engages at approximately 9.6 km/h (6 mph). During shifts the lock up clutch quickly releases and re-engages to reduce power train torque loads. This action provides for smoother shifting, extended component life, and increased operator comfort.

- **Rimpull** at stall is 679 kN (149,694 lb) 20.4 percent gradeability at maximum operating weight.

2 Transfer Case provides torque transfer from the lock-up torque converter to the six speed planetary powershift transmission. The 1.00:1 ratio, four helical gear design proven up to 1900 horsepower ensures extended life between overhauls.

3 Six speed planetary power shift transmission is designed for the higher horsepower of the 3516B engine. The design makes the transmission more robust, when used with the 3512B HD engine and provides extended life between overhauls.

- The transmission utilizes a dedicated oil tank and circuit for cooler, cleaner oil and extended component life.

4 Large differential and final drives provide torque multiplication of 18.44:1 to further reduce stress on the drive train.

Bolt-on Rims, cast rear wheels and Cat 789 rear wheel bearings are utilized to minimize maintenance and provide outstanding durability.

Engine/Power Train Integration

Information from the engine and transmission work together to maximize production, efficiency and extend service life of the components.

The **CAT Data Link** electronically connects the engine and transmission controls to optimize overall power train performance, reliability and component life for reduced power train operating costs. To lower operating cost per ton the system incorporates:

- **Controlled throttle shifting.** Engine rpm is regulated during a shift to reduce driveline torque stress for smoother shifts, extended component life and improved operator comfort.
- **Directional shift management** regulates engine speed during directional shifts to prevent damage caused by high speed directional changes. This prevents shifts into reverse when forward ground speeds are in excess of 4.8 km/h (3 mph). This protects the transmission from high shock loads created by abusive directional shifts.
- **Neutral coast inhibitor** prevents the transmission from shifting to neutral at speeds above 6.5 km/h (4 mph). This protects the transmission against operating with insufficient lubrication.
- **On grade shift inhibitor** prevents the transmission from cycle shifting while the vehicle is traveling up a ramp that exceeds the preset grade.
- **Engine overspeed protection.** The transmission control senses possible overspeed conditions and up shifts one gear. If overspeed conditions occur in top gear, the lock up clutch is disengaged.
- **Programmable top gear.** The transmission top gear may be electronically set using ET. This feature helps operators maintain speed limits. Reprogramming of the top gear can only be accomplished with the ET service tool.

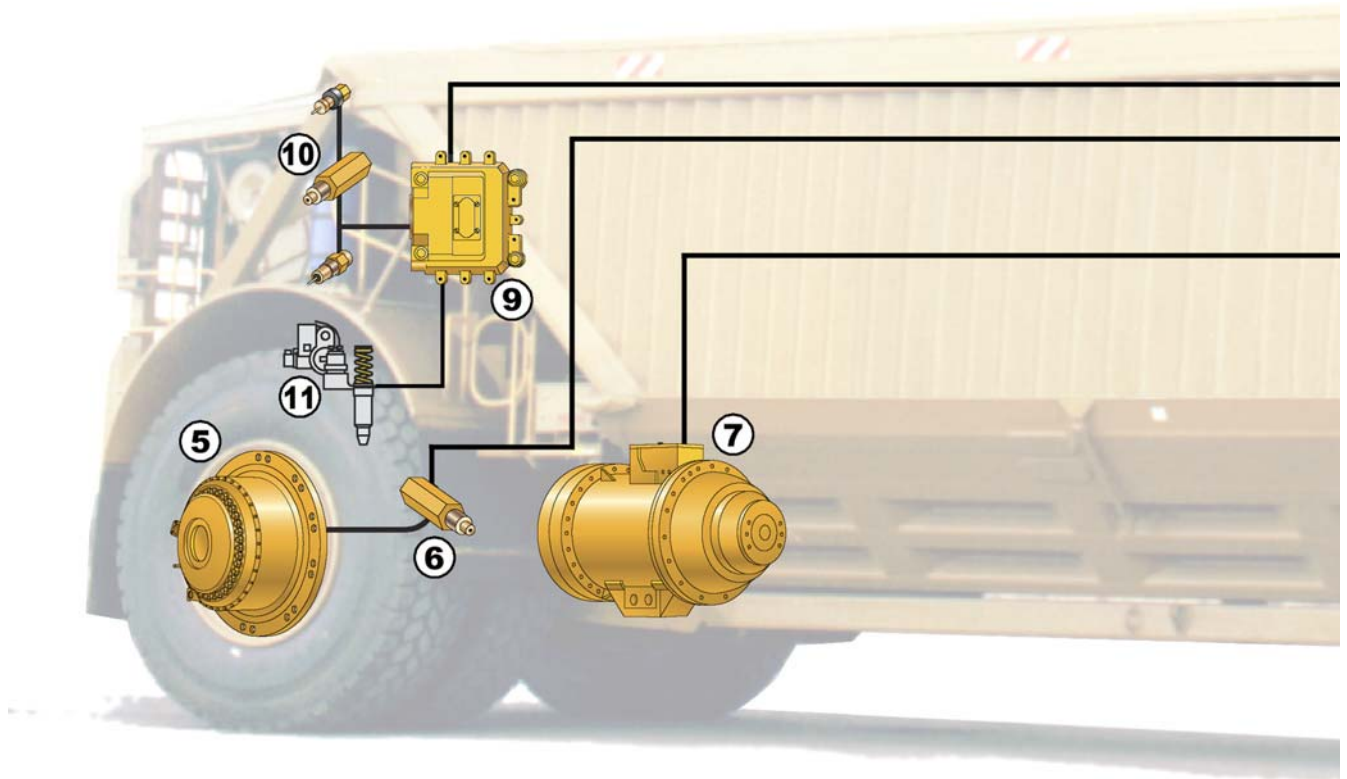

- **Anti-hunt function.** The transmission will not allow an upshift or downshift for approximately 2.3 seconds after a shift has occurred. This prevents gear hunting when operating near a shift point and minimizes transmission shifts to increase component life.
- **Downshift inhibitor.** The transmission will not allow a down shift to occur until engine speed reaches the downshift point, preventing an engine overspeed condition.
- **Electronic Technician (ET)** allows for easy access to service diagnostic data through the use of a single service tool.
 - ET accesses data stored in the engine and transmission controls via the CAT Data Link. Information on transmission shift data, engine speed, fuel consumption and other data can be retrieved by ET.
- **Integrated Braking Control (IBC)** combines braking control enhancements into one system for efficiency and simplification. IBC systems, Automatic Retarder Control (ARC), and the optional Traction Control System (TCS) both utilize the standard oil cooled disc brakes in their operation.
- **Improved diagnostics/serviceability.** The electronic engine and transmission controls provide enhanced diagnostic capability. The ability to store both active and intermittent indicators simplifies problem diagnosis and reduces total repair time, resulting in improved mechanical availability and lower operating cost.

- 1 Gauge Cluster Module
- 2 Message Center Module
- 3 Integrated Braking Control (IBC)
- 4 Transmission/Chassis Control (TCC)
- 5 Brakes
- 6 Wheel Sensor
- 7 Transmission
- 8 CAT Data Link
- 9 Engine Control Module (ECM)
- 10 Sensors
- 11 Electronic Unit Injector(EUI)

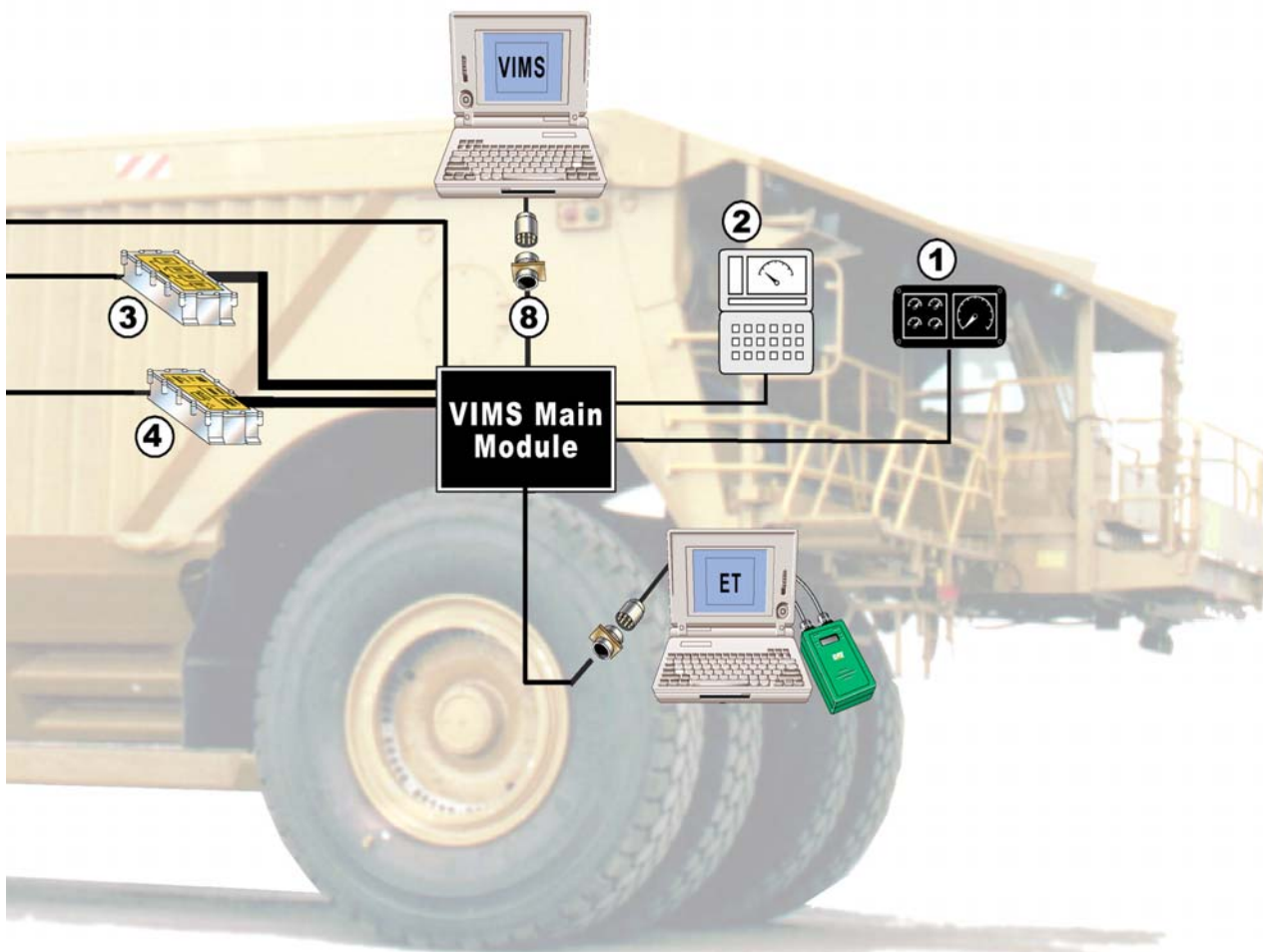

Oil cooled Disc Brakes

Reliable braking gives operators' the confidence to concentrate on truck operation and maximize productivity.

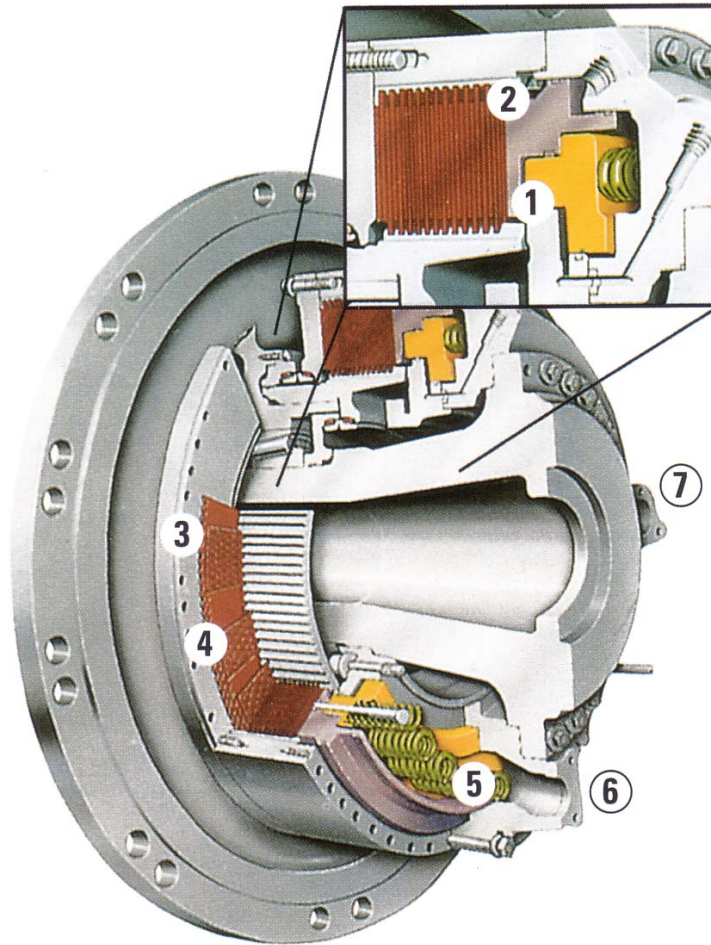

- 1 Parking/Secondary Piston
- 2 Service/Retarding Piston
- 3 Friction Discs
- 4 Steel Plates
- 5 Actuating Springs
- 6 Cooling Oil In
- 7 Cooling Oil Out

Caterpillar forced oil-cooled, multiple disc brakes are continuously cooled for exceptional, non fade braking and retarding. The Integrated Braking Control (IBC) combines control of ARC and TCS, utilizing standard oil cooled brakes to enhance truck performance and increase productivity.

793C oil cooled rear disc brakes are designed with large discs and plates for reliable, adjustment free operation, providing superior performance and service life in comparison to shoe type brake systems.

An oil film prevents direct contact between the discs. The film absorbs the braking forces by shearing the oil molecules. The heat generated is transferred to the oil and carried away to oil coolers, extending brake life.

Slotted Steel Plates are used to improve oil flow and extend brake plate life.

Caterpillar's patented, two piston design combines the service, secondary, parking brake and retarding functions in the same robust system.

- **The primary piston** is hydraulically actuated and provides both service and retarding functions.
- **The secondary piston** is spring applied and is held in the disengaged position by hydraulic pressure.

- **The brake system** is designed so that, in the event hydraulic system pressure drops below a specified level, the spring applied secondary piston automatically applies the brakes. These brakes are designed to exceed all industry standards.

No fuel is used during retarding. The engine provides additional retarding by running against compression on downhill hauls. During retarding applications the engine ECM does not inject fuel into the cylinders for exceptional fuel economy.

Integrated Braking Control (IBC)

Electronically combines Automatic Retarding Control (ARC) and the optional Traction Control System (TCS) into one integrated control system.

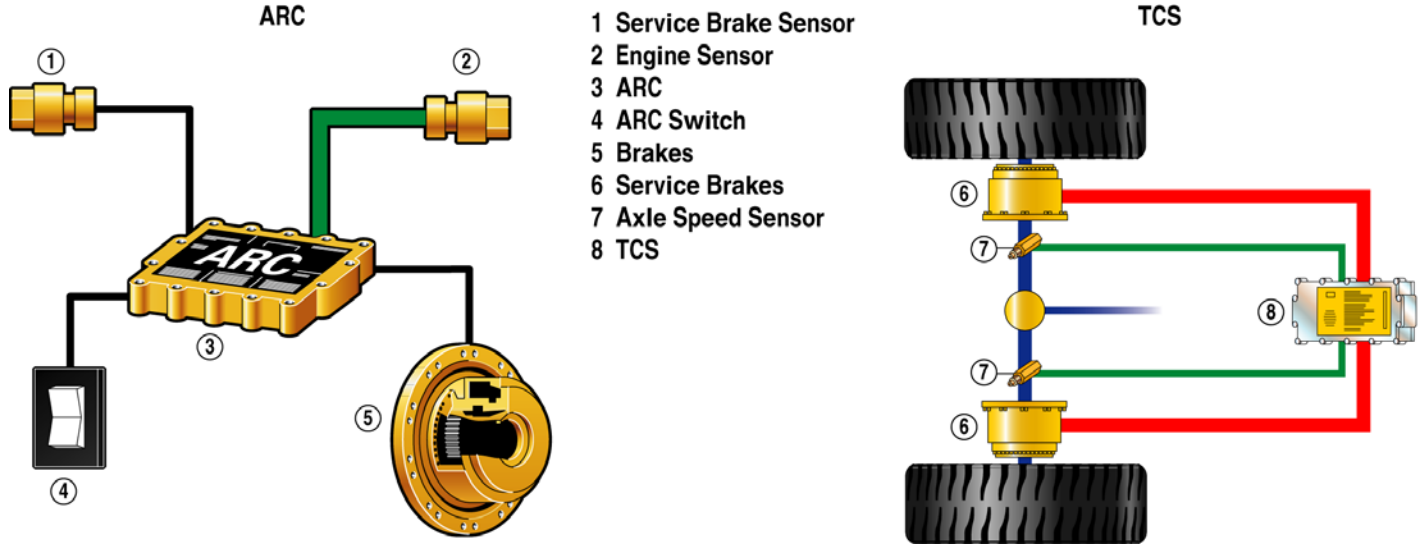

The **Automatic Retarder Control (ARC)** is an integral part of the intelligent power train. It electronically controls retarding on grade to maintain optimum engine rpm and oil cooling. Settings are adjustable from 1950-2050 rpm in increments of 10 rpm. While ARC modulates the brakes, the operator may also apply additional braking force using either the manual retarder or the brake pedal. When the operator applies the throttle, ARC is deactivated. An auto resume feature reactivates the control without additional operator input.

ARC results in:

- **Increased production** with faster downhill speeds. By maintaining consistently higher engine speeds, overall truck speed will be higher than a manually controlled truck.
- **Excellent controllability and reduced operator effort.** Automatic brake modulation provides a smoother ride, better control in slippery conditions and allows the operator to focus more on driving.
- **Faster troubleshooting and diagnosis** with self-diagnostic capability and the ability to communicate with ET through the CAT Data Link.

Reduced operator fatigue resulting from ease of operation.

- **Engine overspeed protection.** ARC will automatically activate when engine speed exceeds factory preset levels, regardless of other operator inputs, including when the system is turned "off", to help ensure that overspeed conditions do not occur.

ARC production advantages (versus manual retarder control) are illustrated in the chart below.

- ARC can increase vehicle speed by as much as 15 percent over manual retarder control.
- The system allows trucks to operate at maximum speeds with a consistently high engine speed.
- Truck handling is significantly enhanced through improved retarding modulation.

Traction Control System (TCS) (optional) improves traction and truck performance in poor underfoot conditions by electronically monitoring and controlling rear wheel slippage.

- Axle sensors monitor wheel speed. If slippage exceeds a set limit, the oil-cooled disc brakes engage to slow the spinning wheel. Torque is then automatically transferred to the wheel with better traction.
- Utilizes normal differential action to provide superior maneuvering in poor underfoot conditions. Should the sensors fail, normal differential action is still available to maintain control and steering.
- Operators feel more confident with the anti-slip benefits provided by the TCS.

ARC Operating Efficiency Advantages

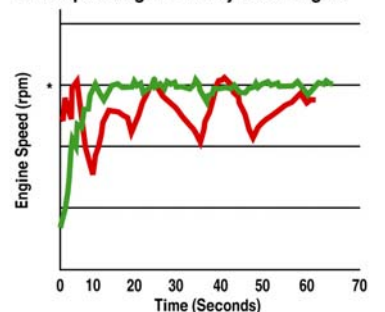

Automatic Retarder Control
(Maintains Engine rpm between 2160-2300)

Manual Retarder Control
(Wide Variation in Engine rpm)

* Optimum Engine rpm

Operators Station

Control the truck with ease and comfort to maximize productivity.



The operating station on the 200C II is ergonomically designed for excellent machine control in a comfortable, productive, and safe environment.

Exceptional all around visibility reduces strain and fatigue allowing confident maneuvering and increased productivity.

Integral, sound suppressed Cab is standard. The cab is isolator mounted to protect the driver from sound and vibration. (Sound levels are less than 80 dB (A) in the operator compartment as per SAE J 1166 work cycle rating.)

1 Ergonomically designed, air suspension seat is fully adjustable for operator comfort.

- Retractable 75 mm (3") wide seat belt provides positive, comfortable restraint.
- Integral adjustable armrest.

2 Retarder actuator is located on the floor to provide easy operator control.

3 Service Brake Pedal is located on the floor to provide easy operator control.

4 VIMS displays and operator key pad for precise machine status information.

5 Tilt and telescoping steering wheel improves operator access and comfort.

6 Transmission console has been redesigned with backlit gear indicators and ergonomic shift knob.

7 Storage compartment located under the trainer seat.

8 Trainer seat has wide hip and shoulder room. A back rest and seat belt are standard.

9 Powered operator window is standard. Sliding trainer seat window is standard.

10 Operator controls for turn signal, high beam, intermittent windshield wiper, windshield washer and horn have been redesigned for operator efficiency and comfort.

11 Standard heater and air conditioner have a more efficient design, permitting increased flow, modulation, and service ability. These systems provide fresh, pressurized, temperature controlled air circulation.

Radio ready cab prewired with power converter. Power outlets provide for electrical devices.

Total Customer Support and Servicability

Kress machines are designed to spend less time down for maintenance allowing more time on the job.



Parts availability. Most Kress and Cat parts are immediately available off the shelf. Kress Dealers rely on Cat's worldwide computer network to find parts instantly and minimize your machine downtime.

Flexible financing. Your dealer can arrange attractive financing.

Machine management service. Dealers help manage your equipment investments with:

- Vehicle systems analysis to match the right machine to your job conditions.
- Effective preventive maintenance programs.
- Diagnostic programs like Scheduled Oil Sampling Analysis and Technical Analysis.
- Exchange components for quick repairs.
- Remanufactured products or rebuilt components for maximum availability and lower costs.
- Information to make the most cost effective repair option decisions.
- Training for operators and mechanics.

Literature support. Operation and maintenance manuals are easy to use helping you get the full value of your equipment investment.

Remanufactured components are economically available for many Caterpillar and Kress components.

Ground level access provides convenient servicing to tanks, filters and compartment drains, as well as engine shutdown capability.

Caterpillar Electronic Technician (ET) accesses machine data easily. It quickly runs tests, makes calibrations and retrieves system data to help find and correct problems before they become costly failures.

Easy Access to many routine maintenance items.

Optional - automatic lubrication system provides grease to necessary components on a regular basis to reduce maintenance and improve machine availability.

Fast fill fuel system (Wiggins)

Optional - Fast fill oil & coolant system (Wiggins)

Scheduled Oil Sampling S•O•SSM valves speed sampling and analysis reliability.

Oil Renewal System (ORS) is an option available which extends oil change intervals and reduces waste oil handling by continuously burning oil from the sump through normal engine operation. Make up oil must be added to compensate for oil burned.

Individual, interchangeable engine cylinder heads can be removed easily for visual inspection of internal parts.

In frame access allows maintenance and minor repairs without major component removal. It also facilitates major component removal and replacement, if necessary.

Quick coupler pressure taps are located in most hydraulic systems providing clear, quick pressure checks and diagnostics.

Radial seal air filters are easy to change, reducing time required for air filter maintenance.

Sealed electrical connectors lockout dust and moisture. Wires are coded for easy diagnosis and repair. Wiring harnesses are braided or have a protective sheath to prevent damage.

Body Structure and Suspensions

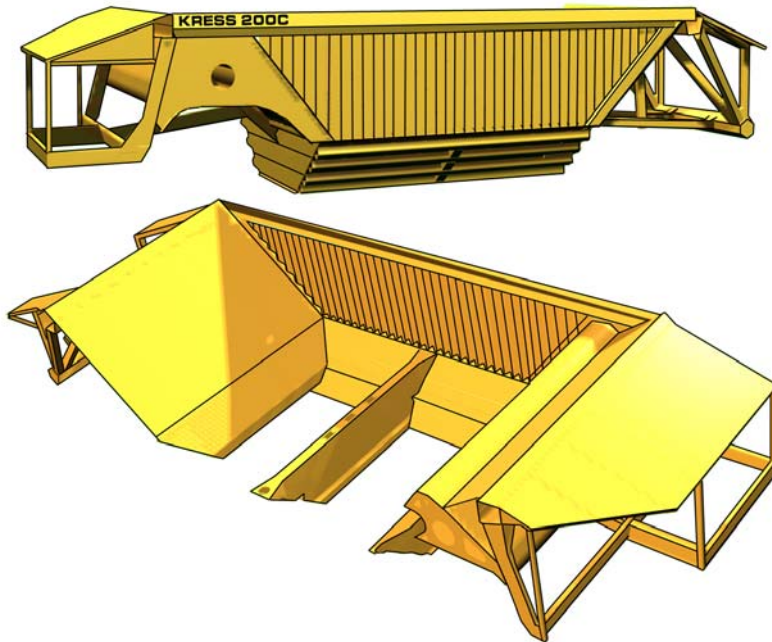

Kress Unitized bottom dump coal haulers set the standard in the industry with the best maneuverability, smoothest ride, increased transport speeds, improved stability, elimination of jackknifing, and by far the **highest payload to weight ratio in the industry. 1.9 to 1**

Unitized body and frame incorporate the following features:

High strength abrasion resistant A514 steels such as T1 [690 mPa (100,000 psi) minimum yield strength] and XAR [360 BHN minimum].

High Strength Alloy Steel Castings [690 mPa (100,000 psi) minimum yield strength] incorporated in critical stress areas.

Integral rear bumper with push block

Front fabricated box beam supports suspension cylinders and ROPS/FOPS support

Box section rear structure supports engine, canopy and upper drive train

Rear Bulkhead integrated into body for attaching suspended drive axle

Sturdy cast tow hooks at each corner to accommodate wire or fiber ropes

Kress Suspensions are by far the industry leader when it comes to smooth ride and eliminating operator fatigue.

Each suspension incorporates:

Dual nitrogen charged chambers to help provide a smooth ride in either loaded or empty conditions for operator comfort and reduced shock loads to the truck body and components.

A spring rate many times softer than tires minimizes tire deflection and prevents heat build up.

The suspensions have **600mm (24")** of travel. This substantially reduces the stress transmitted into the frame when traveling over uneven ground and helps maintain equal load distribution on all tires.

The compensated suspension allows the truck to ride on a soft **300mm (12")** cushion of air both when the truck is loaded and empty. This protects the tires, vehicle, road, and driver.

Tapered sockets used in mounting for secure attachment throughout the life of the components.

Payload measurements accurate within 5%.

The ability to absorb impact shocks during loading.

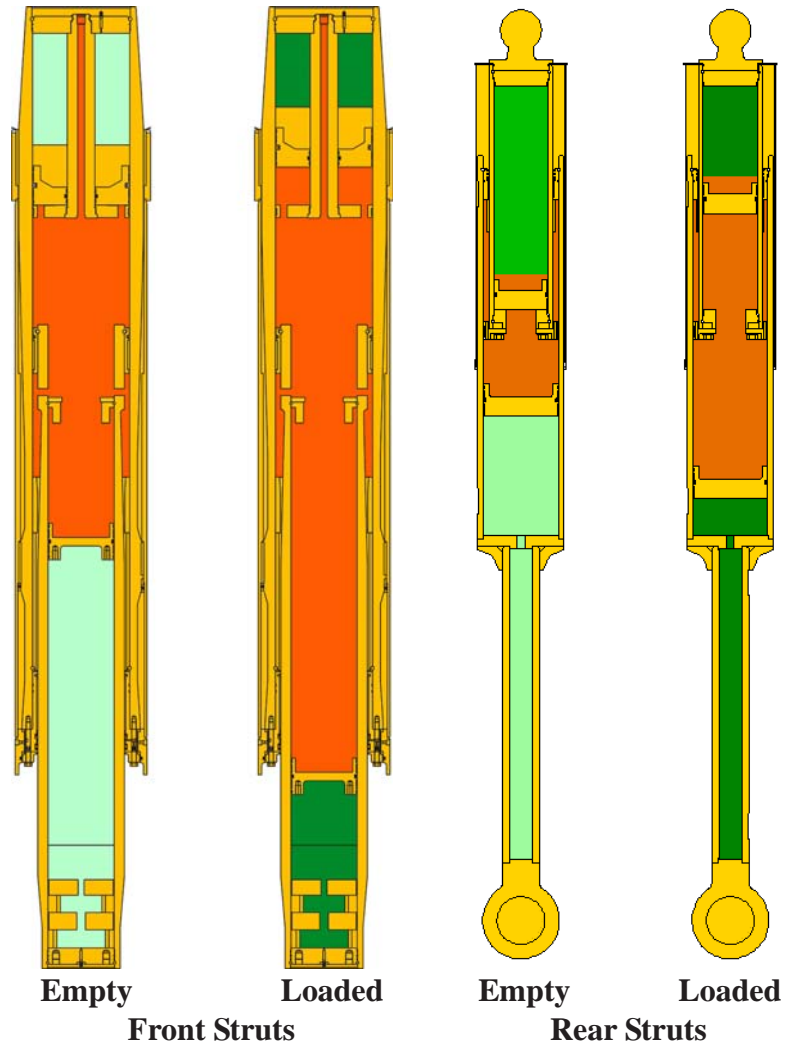

Kress 200C II Features - Unique steering system allows for the unmatched maneuverability

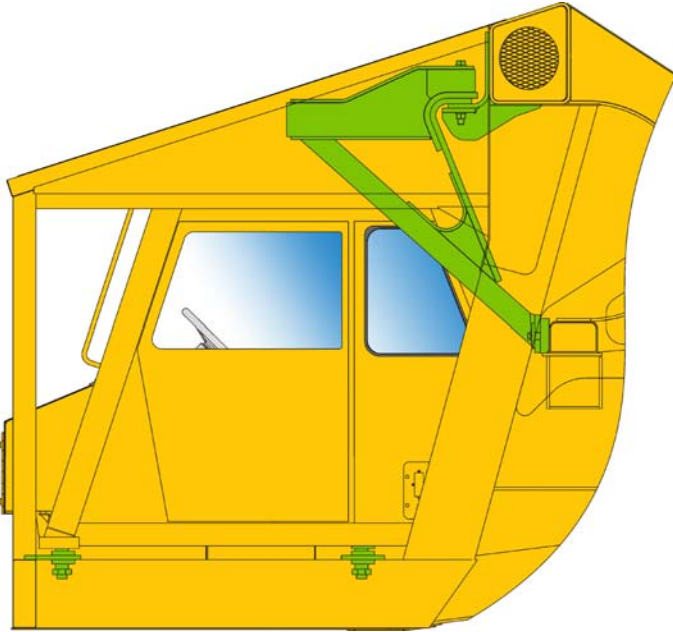

ROPS and Cab Mounting

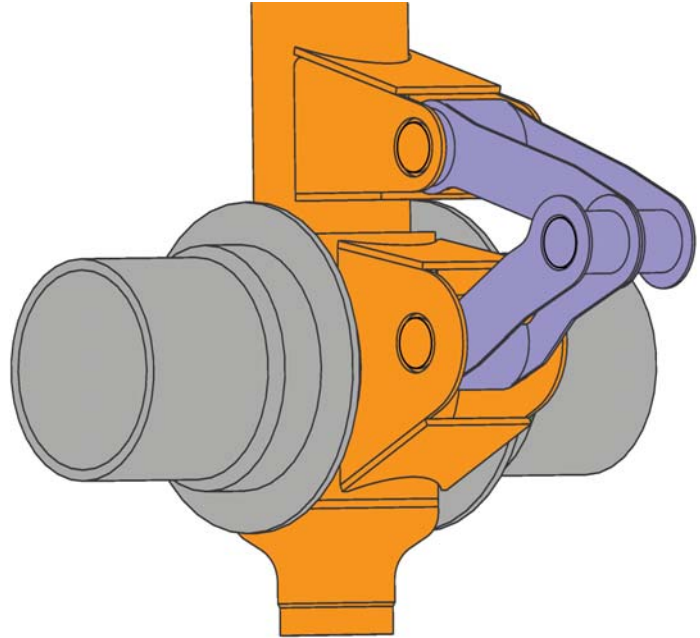

Scissors Links

The Kress unitized bottom dump coal haulers are by far the most maneuverable coal hauler in the industry. Ackerman steering through the whiffle tree steering linkage reduces tire wear and allows steering angles up to 85° for faster spotting.

The unitized truck body allows a means for drawing intake engine air from the front of the truck providing increased air cleaner life.

Modular power train components, including radiator, engine and torque converter, allow easy removal and replacement minimizing downtime during routine maintenance procedures.

Front and Rear canopies protect cab and power train from material damage. Hydraulic rear canopy raises for easier access to powertrain components.

Separate Rollover Protection Structure provides superior operator protection.

Body angle design to reduce material carry back.

Design of Unitized Body to maintain structural integrity over full life cycle of the truck.

High power to weight ratio!

Scissor Links attached to the front struts maintain accurate steering during full suspension travel.

Over Thirty years of vehicle design and application experience.

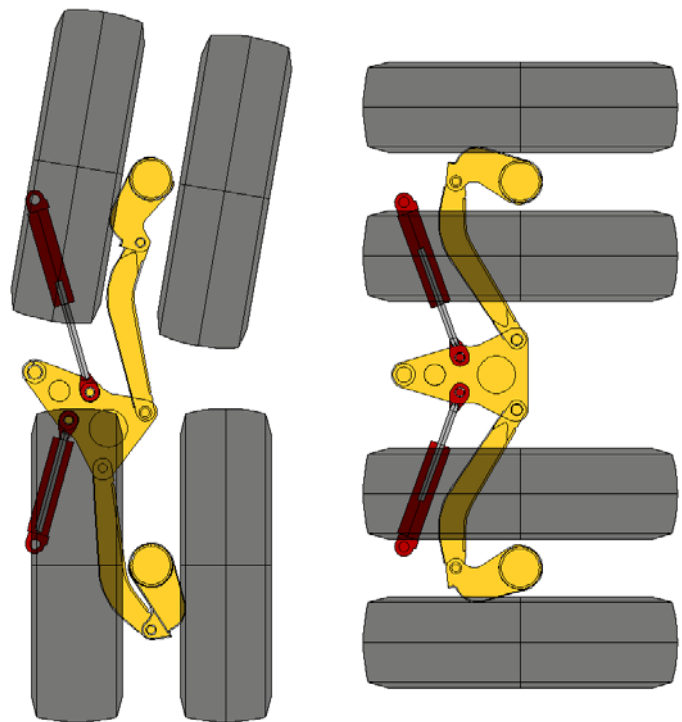

Whiffle Tree & Steering Linkage

Vital Information Management System (VIMS)

Provides operators, service technicians and managers with vital machine and production data.

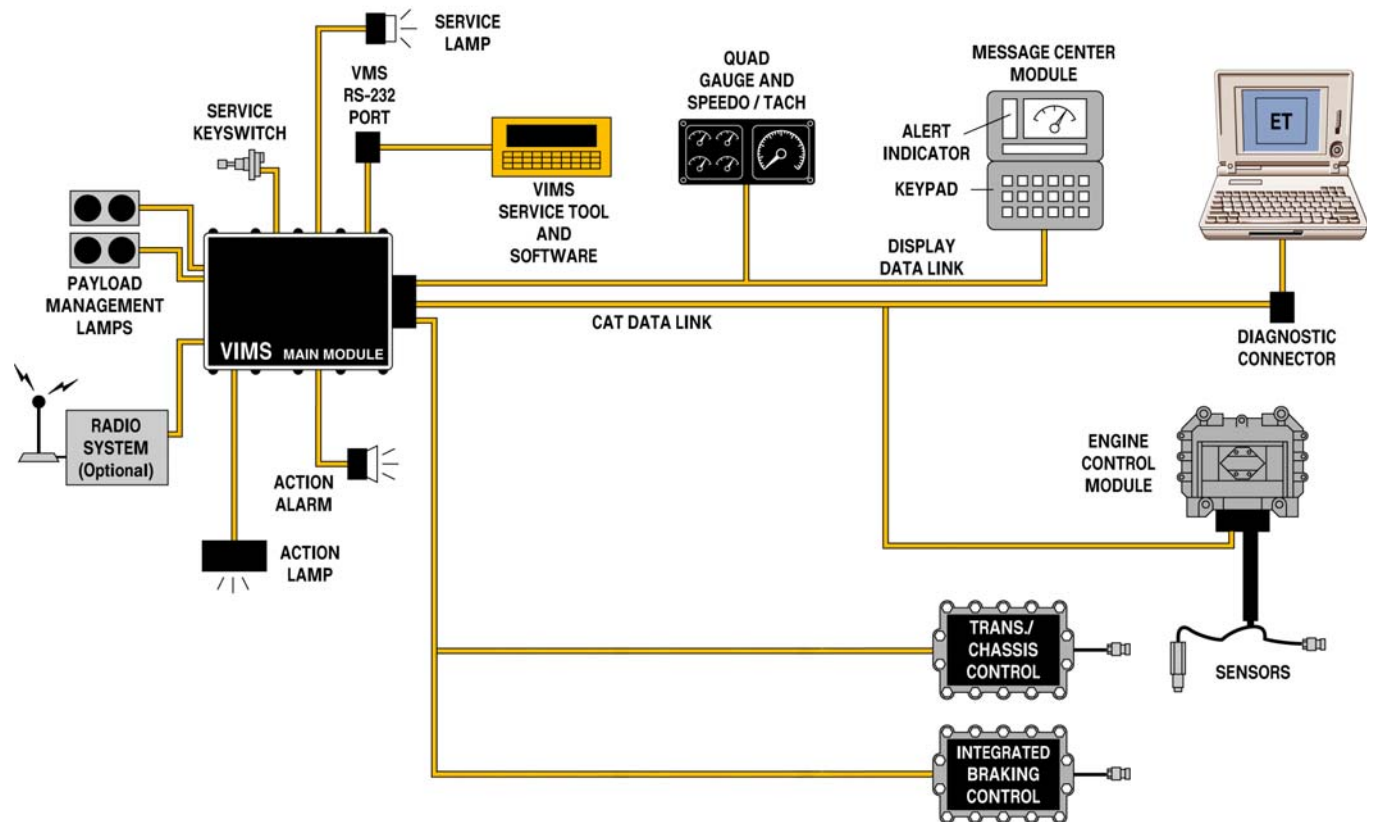

VIMS is an integrated Caterpillar designed system that monitors machine performance to provide critical information on a real time basis. VIMS monitors many of the machine's systems through a single simple system that allows quick exchange of information for smooth, efficient operations. This helps keep the 200C II performing at top production levels.

Gauge cluster in the cab maintains a constant display of several, machine functions:

- Engine coolant temperature
- Brake oil temperature
- Transfer Case Temperature
- Voltage

Speedometer/Tachometer/Gear Indicator

VIMS keypad allows the operator or service technician to access through the message center, gauge values (realtime) and stored information. The keypad can also be used by service personnel to access diagnostic information.

Message center displays operator requested information and utilizes a three category warning system to alert the operator to an abnormal machine condition.

The three category alert system provides advisory information on an exception basis to the operator via the message center on abnormal machine conditions. The information is displayed when conditions in a monitored system fall outside a prescribed setting for ordinary operations.

Category I activates the alert indicator lamp when a system condition has been identified. (*No action is required at this time.*) Usually all that is required is to inform service personnel on the alerted condition as soon as possible.

Category II, a warning lamp (located above the gauge cluster) flashes in addition to the Category I alert indicator lamp in the display panel. Instructions are displayed on how machine operation should be modified or which service should be performed.

Category III, the highest alert, sounds an audio action alert in addition to the Category II alarms. The action lamp and alert remain on until the system readings return to normal or the machine is shut down.

Vital Information Management System (VIMS)

Enhances truck and loader effectiveness for improved fleet availability and reduced operating and maintenance costs

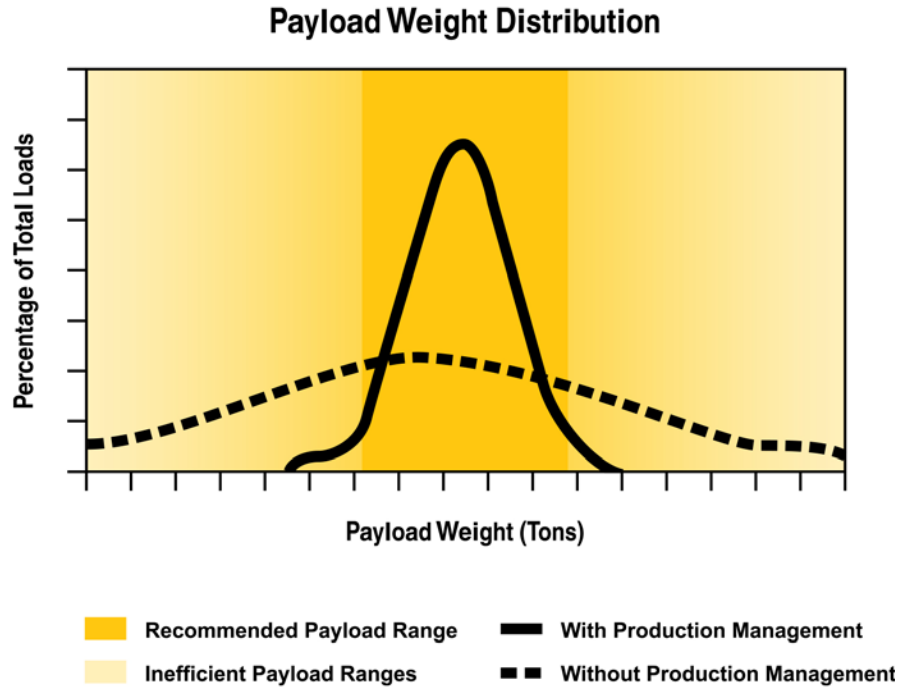

VIMS simplifies trouble shooting, reduces down time and lowers operating costs by allowing minor problems to be corrected before they cause extensive damage. Many sensors are incorporated into machine systems to monitor conditions.

Production management, a feature component of VIMS, enhances truck and loading tool effectiveness for improved fleet productivity and reduced operation and maintenance cost.

- Utilizes Kress/Cat developed technology to sense strut pressure to determine payload weight accurately.
- Maximizes truck production while avoiding future costs and downtime related to overloading.
- Optional external lights on both sides of the truck signal loading tool operator when to cease loading.

- Stores 2400 cycles for a record of payload weight, cycle segment times, cycle segment distances and actual clock time and date of each cycle.
- Data can be accessed through the message center, transmitted via optional radio or downloaded for detailed analysis.

The VIMS off truck software program (VIMS PC) allows service personnel to download a complete record of production information, machine data events and system diagnostics to a laptop computer.

The VIMS PC program uses this information to generate usable reports for better machine management. The information can also be used to establish a baseline for machine performance in specific applications, and to:

- Improve the effectiveness of scheduled maintenance programs.
- Maximize component lives
- Improve machine availability
- Lower cost-per-ton

Well managed mining operations focus on maximizing production and reducing costs, which should result in lower cost per-ton. When used properly, VIMS can be used to increase productivity and reduce costs.

Engine

Four-stroke cycle, 3512B HD twin turbocharged and aftercooled diesel engine

Engine

Four stroke cycle, 3512B HD twin turbocharged and aftercooled diesel engine

Table 1: Ratings at

	kW	hp
Gross Power	1268	1700
Net Power	1197	1605

The following ratings apply at 1750 rpm when tested under the specified standard conditions for the specified standard.

Table 2: Netpower

Net Power	kW	hp
Caterpillar	1197	1605
ISO9249	1197	1605
SAEJ1349	1197	1605
EEC 80/1269	1197	1605

Table 3: Dimensions

Bore	170mm	6.7 in
Stroke	215 mm	8.5 in
Displacement	58.6 liters	3,572 in ³

Final Drives

Planetary, full-floating

Ratios (standard):

Differential	2.35:1
Planetary, single reduction	7.85:1
Total reduction	18.44:1

Power Rating Conditions

- based on standard conditions of 25° C (77°F) and 99kPa (29.32 in Hg) dry barometer.
- used 35° API gravity fuel having an LHV of 42,780 kJ/kg (18,390 Btu/lb) when used at 30°C (86° F) [ref. a fuel density of 838.9 g/L(7.001 lb/ U.S. gal)
- net power advertised is the power available at the flywheel when the engine is equipped with fan, air cleaner, muffler and alternator
- no derating required up to 3048 m (10,000 ft) altitude.
- automatic derate is included in the electronic controls.

Features

- full electronic control
- high pressure Electronic Unit Injection
- two hard faced intake and two exhaust valves per cylinder with valve rotators and hard, alloy steel seats.
- self aligning roller followers on cam shaft
- two piece pistons have steel crowns, thermally isolated aluminum skirts, three rings each and are cooled by dual oil spray.
- steel backed, copper bonded crank-shaft bearings.
- hardened crankshaft journals
- dry type air cleaners with primary and secondary elements and precleaner
- 24 volt electric system with 150 amp alternator and four 100 amp hour, low maintenance, high output, 12 volt batteries.
- two electric starters.

Transmission

Caterpillar six speed, electronically controlled, automatic power shift transmission.

Table 1: Maximum travel speeds (36.00-R51 tires & 18.44:1 final drive ratio)

2000 rpm	gear	km/h	mph
Forward	1	16.3	10.1
	2	21.8	13.5
	3	29.6	18.4
	4	40.0	24.9
	5	54.3	23.7
	6	73.5	45.7
Reverse		14.7	9.1

Features

- six speeds forward and one reverse
- reverse is torque convertor driven
- first gear has both torque converter drive and direct drive
- second through seventh gears are direct drive
- single-lever shift control provides automatic shifting in all gears up to the one selected by the control lever
- each shift is individually modulated for maximum smoothness
- separate hydraulic circuit with cooler diagnostics and facility code memory, event memory and programmable features
- Controlled Throttle Shift (CTS)
- Directional Shift Management
- Neutral Coast Inhibitor

Brakes

Meets SAE J1473 OCT90, ISO 3450 Jan 98

Rear Braking surface 134,590 cm² (20,861 in²)

Features

- Service:
 - forced oil cooled
 - oil actuated
 - front dry disc brakes
 - rear wet slotted disc brakes
 - sealed from dirt and water
 - individually serviceable as units
- Retarding System:
 - Foot operated pedal provides modulate engagement of service brakes for retarding
 - Automatic Retarder Control (ARC) optional

•Secondary Braking:

- spring engaged, hydraulically released
- use rear disc brakes in service system

•Parking Brakes:

- spring engaged, hydraulically released
- use rear disc brakes in service system
- switch activated

•Traction System:

- minimize wheel slip by transferring torque to wheel with traction
- Traction Control System (TCS) optional

Unitized Body & Frame

High strength low alloy steels allow unit to withstand years of demanding haulage.

Features

- Fully unitized body and frame giving a lighter truck with better performance.
- Frame design allows for superior structural integrity by supporting weight of truck equally on all corners of the truck. Frame is designed to take the most abusive conditions throughout the coal handling industry.
- Design incorporates use of high yielding A514 plate allowing use of thinner plate resulting in an overall lighter frame than competitors.
- Sturdy tow points positioned around the machine.
- Front, Center and Rear Bulkheads integrated into the unitized body for strength, component protection and durability.

Suspension

Independent Nitrogen/Hydraulic Charged

Features

- Each suspension cylinder utilizes separate Nitrogen charged chambers to provide an ultra smooth ride in either the loaded or empty conditions.
- Front suspension cylinders are mounted into tube frame using tapered sockets providing secure attachment throughout machine life.

Effective cylinder stroke:

Front	900mm	36"
Rear	600mm	24"

Dump Doors & Cylinders

Double acting hydraulic cylinders

Features

- Dump Doors are hung with linkages providing long lasting trouble free operation along with eliminating cylinder side loading.
- Door Linkages maximize door opening and ground clearance for stockpiling.
- Controlled door opening to optimize stock piling performance.

ROPS/FOPS

ROPS structure

Features

- ROPS (Rollover Protection Structure) offered by Kress for the machine meets ROPS criteria SAE J 1040 APR8 8, SAE J231 JAN8 I & ISO 3471 1994, ISO 3449-1992 LEVEL I I.
- FOPS (Falling Object Protective Structure) offered by Kress for the machine meets FOPS criteria SAE J231 JSN 81 & ISO 3449-1992 Level 11
- When properly installed and maintained, the cab offered by Caterpillar when tested with doors and windows closed as per work cycle procedures specified in ANSI/SAE J1166 MAY90, results in an operator sound exposure Leq equivalent sound level) of less than 80 dB(A) This operator weighted sound exposure meets OSHA and MSHA occupational noise exposure criteria.

Tires

Standard: 36.00R51
Optional: 33.00R51

Features

- Productive capabilities of the 200C II are such that, under certain job conditions, TKPH/TMPH limits of the tires could be exceeded and therefore, affect production.
- Kress recommends that all job conditions be evaluated for proper tire selection & operating pressures.

Rear Canopy

Hydraulically actuated to aid in engine bay serviceability

Features

- Allows Engine to cool quickly
- Permits easy access to the top of the engine and to components, in the engine compartment

Steering

Dual Steering Circuits

Features

- The steering system is charged by two separate systems/circuits.
- Both circuits incorporate four piston accumulators with a total capacity of 184.7 L (48.8 gal.) Both circuits/systems meet SAEJ1511 Oct1990 and ISO5010-1984 standards for the max operating weight of the 200C II.
- Twin, double acting cylinders
- Road width required for 180° turn (standard tires) - 21.1m (69'4")
- Wall width required for 180° turn (standard tires) - 23.6m (77'6")
- Machine clearance turning circle (standard tires) - 34.2m (112'3")
- Ackerman steering allows steering angle of up to 85° and minimized tire wear.

Rear Axle

Dual Torsional Tube Frame

Features

- Fabricated Dual Torsional Tube Frame utilizes high strength alloy steels and A106 tubes.
- Precision machined to provide accurate component alignment.
- Easily accessible from the side and rear for inspection or removal.

Sound Rating

Features

Exterior-

- This machine in a standard configuration, when measured and operated as per the prescribe modes in ANSI/SAE J88 JUN86, has a 15m sound pressure level of (TBA) db(A) for the mode that gives the highest level.

Interior-

- Due to the rear mounted engine design, decibal levels less than 75db(A).

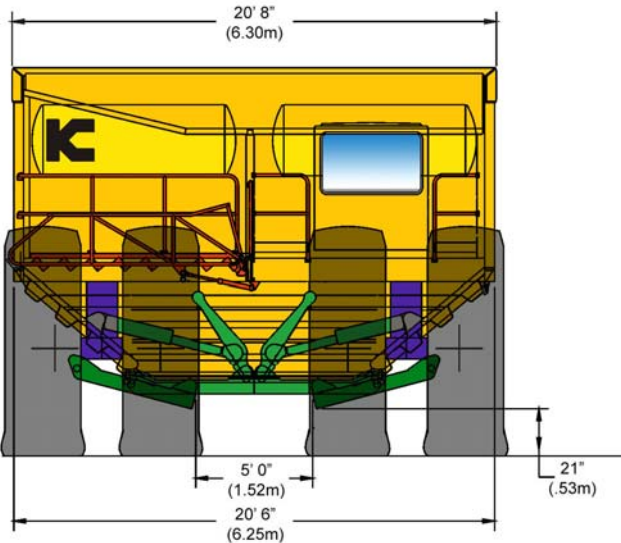
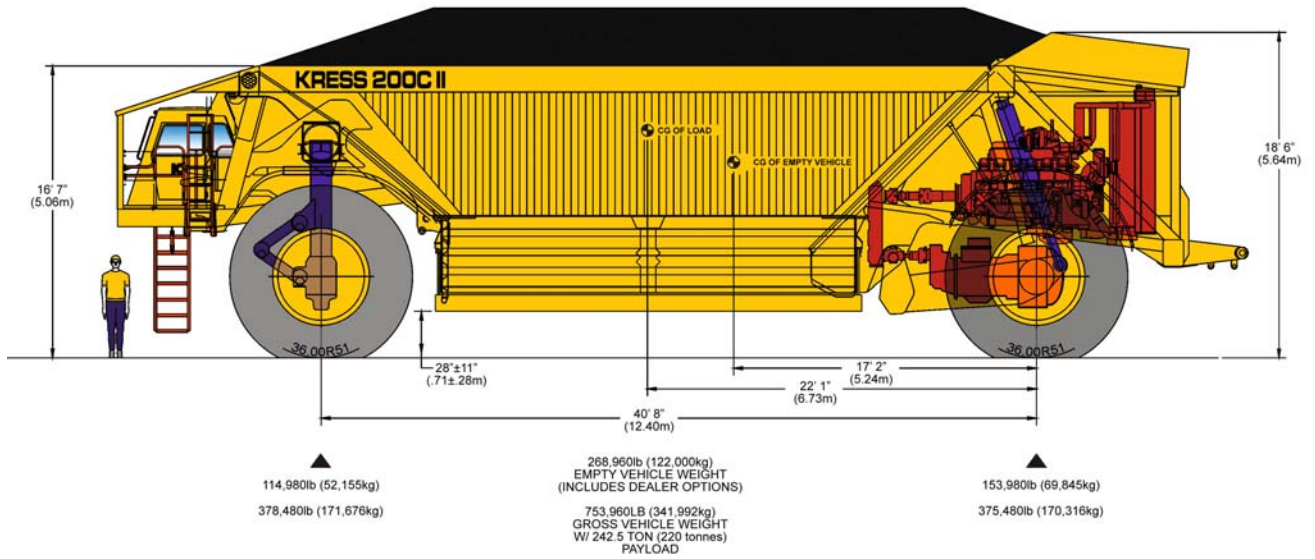
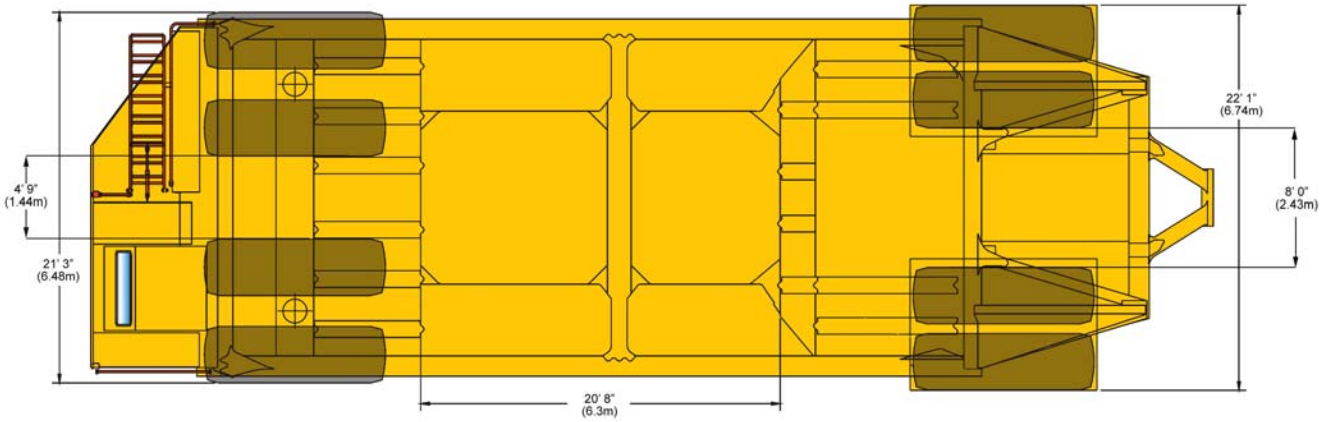

Kress has multiple truck body length configurations to maximize your productivity based on the density of your haulage material.

Dimensions		
Capacity	220 Tonnes	240 Tons
Struck	247m ³	323yd ³
Heaped 3:1 SAE	291m ³	380yd ³
Heaped 2:1 SAE	313m ³	410yd ³
Empty Loading Height	5080mm	16' 8"

Service Refill Capacities		
	L	Gallons (US)
Fuel Tank	2,801	740
Cooling System	663	175
Crankcase	204	54
Differential	143	38
Front wheels (4), each	6.2	1.63
Final Drives (2), each	238.5	63
Hydraulic Tank	908	240
Hydraulic System (includes tank)	1325	350
Transfer Case only	17	6
Transfer Case (including lines)	25	9
Transmission/Hydraulic Tank	106	28
Transmission System (includes tank)	246	65

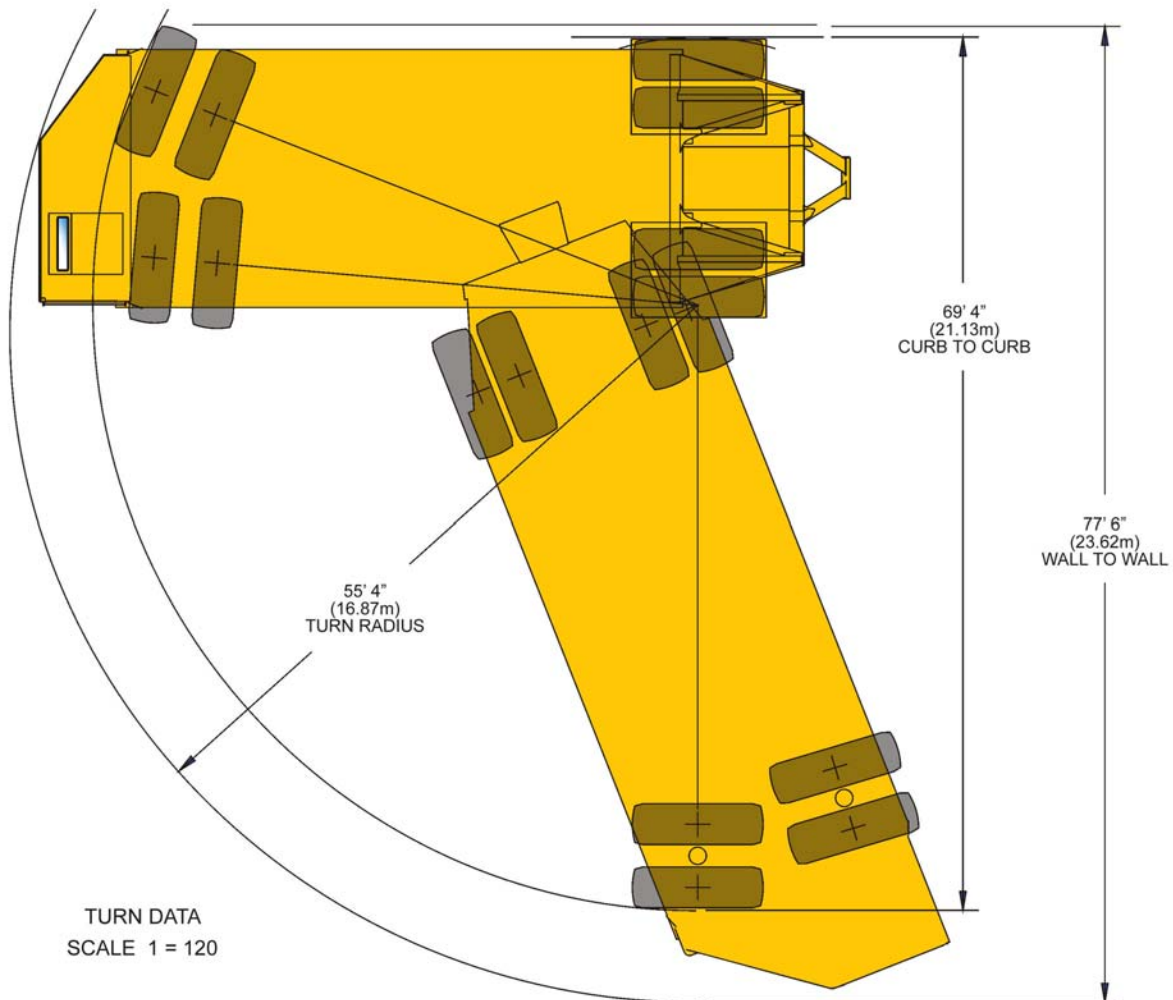

Gradeability/Speed Rimpull

To determine gradeability performance: Read from gross weight down to the percent of total resistance. Total resistance equals actual percent grade plus 1% for each 10 kg/t (20lb/ton) of rolling resistance. From this weight resistance point, read horizontally to the curve with the highest obtainable gear, then down to maximum speed. Usable rimpull will depend upon traction available and weight on drive wheels.

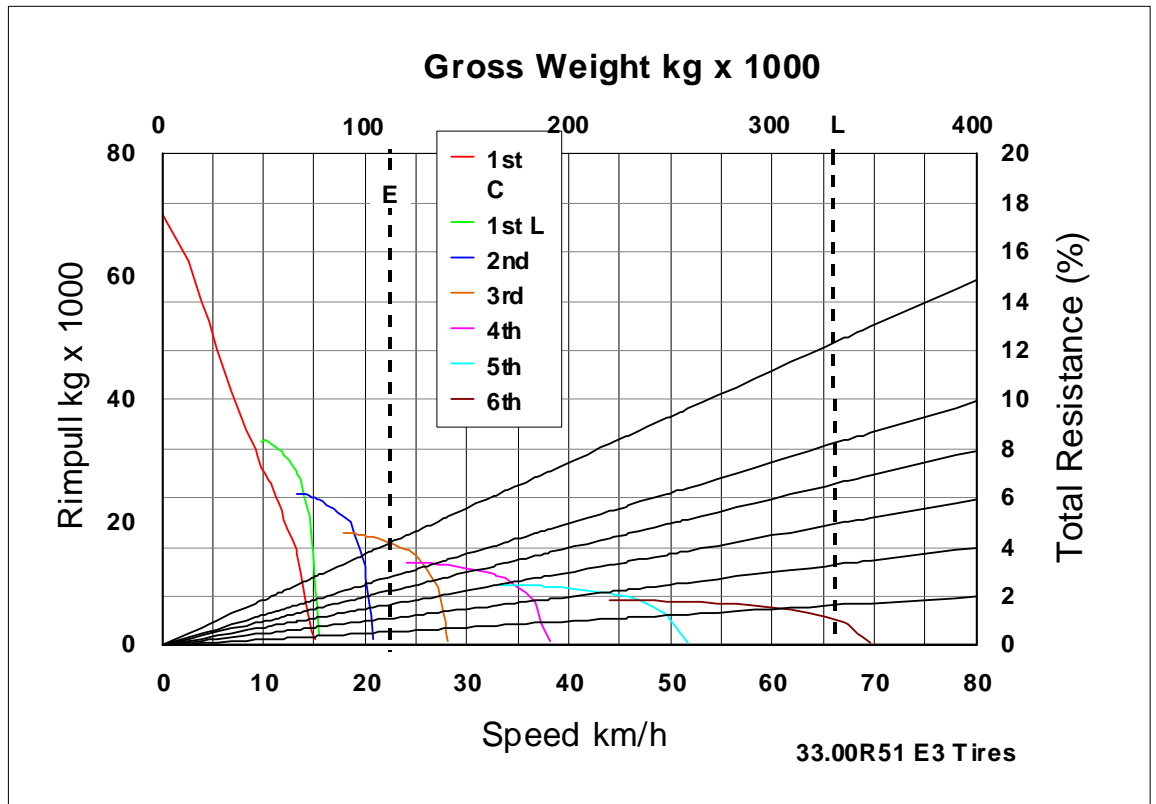
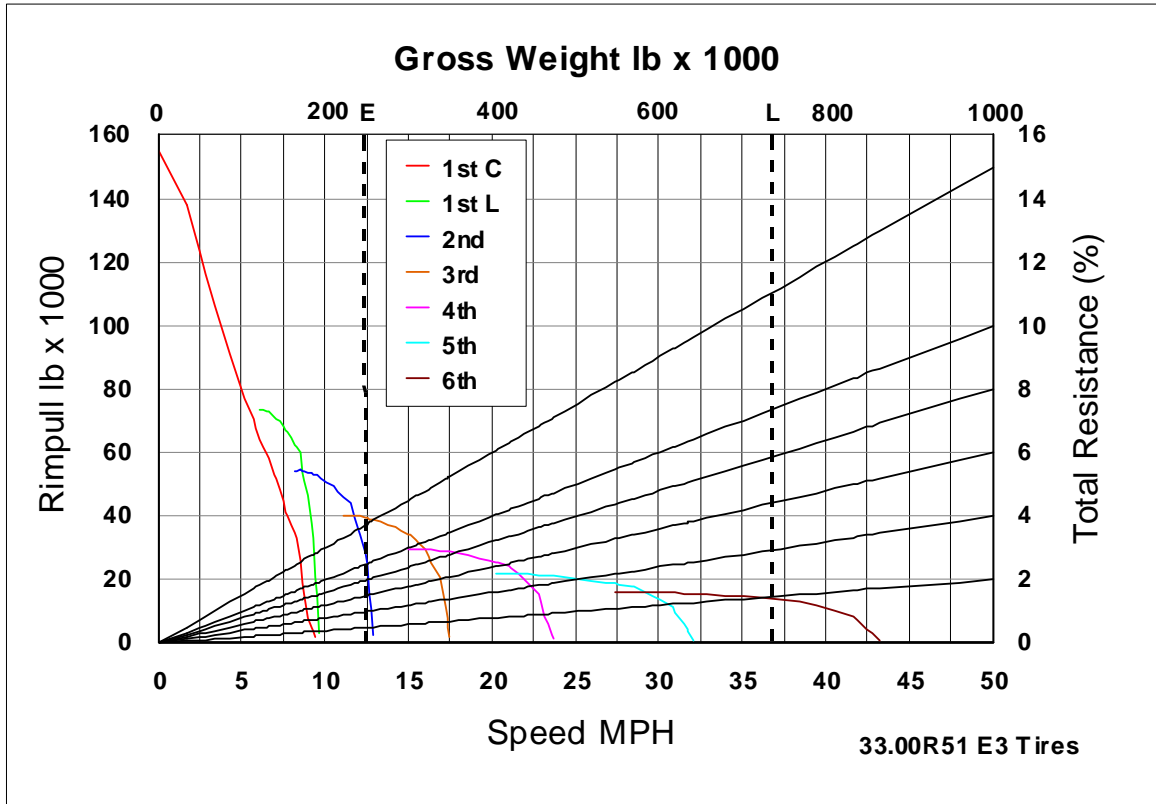

Retarding Performance

To determine retarding performance: Add lengths of all downhill segments and, using this total, refer to proper retarding chart. Read from gross weight down to the percent effective grade. Effective grade equals actual % grade minus 1% for each 10kg/t (20lb/ton) of rolling resistance. From this weight-effective grade point, read horizontally to the curve with the highest obtainable gear, then down to maximum ambient temperature, at sea level, with 33.00R51 tires.

NOTE: Select the proper gear to maintain engine rpm at the highest possible level, without overspeeding the engine. If cooling oil overheats, reduce ground speed to allow transmission to shift to the next lower speed range.

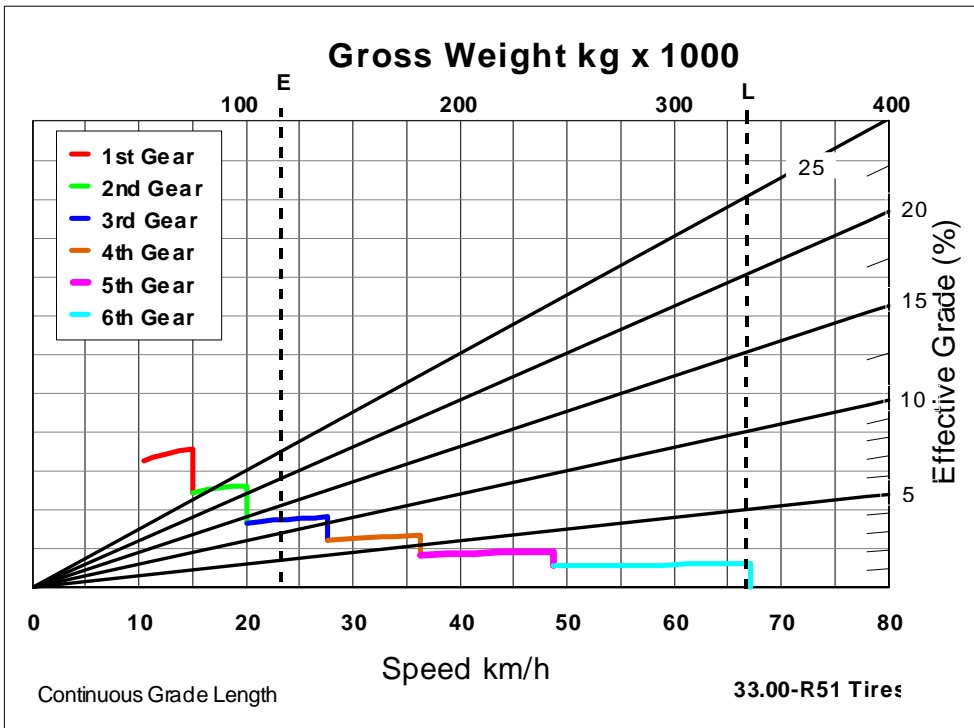
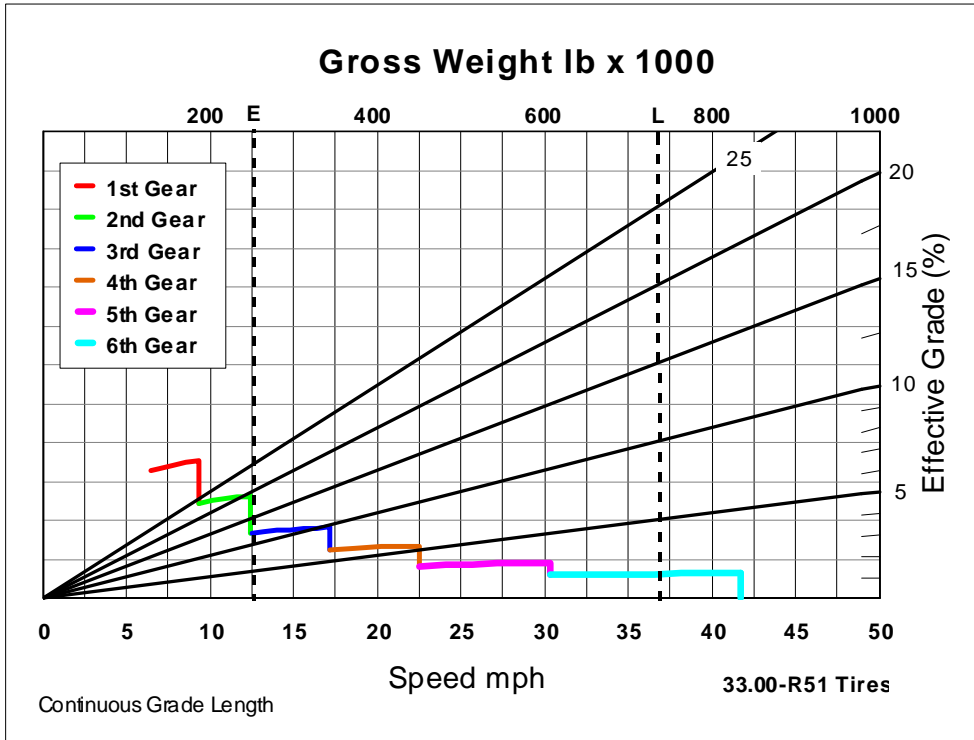

Standard Equipment *(Standard equipment may vary. Consult your Kress/Caterpillar Dealer for specifics.)*

Air cleaner (2) Elements (4)	Steering, automatic supplemental Steering wheel, tilt, padded, telescopic Storage compartment Sun visor Tachometer	Oil sampling ports Push Block
Air conditioner	Transmission gear indicator VIMS Dataport VIMS Keypad VIMS Message Center with Universal Gauge	Radiator, Mesabi® V-core Reservoirs (separate): Hydraulic Transmission
Alarm, back up		Rims, bolt on for 36.00R51 R51 tires (8)
Alternator (150 amp)		
Automatic Retarder Control		
Batteries, 100 amp hour, low maintenance, 12 volt (6)	Driveline Safety Guard	
Brake system: Oil cooled, multiple disc rear, dry disk front Parking Secondary, emergency	Dump door opening limit switch with operator override switch Electrical Starter (2) Electrical system, 24 volt to 12 volt	Steering, auxiliary quick connect for towing Suspension: Hydraulic/ Nitrogen charged – fully compensated automatic leveling system to maintain optimum ride height
Cab, ROPS/FOPS: Auxiliary Power Receptacle, 12 volt (2) Cigarette lighter, 12-volt Coat hook Diagnostic connector Electric window (operator only) Glass, tinted Heater/defroster Horn Insulated and sound suppressed Light, dome Mirrors, right and left Quad Gauge Panel: Engine Coolant Temperature Brake Oil Temperature Transfer Case Temperature Battery Voltage Seat, air suspension Seat, passenger, with storage area Seat belts (Retractable) Speedometer	Engine: Caterpillar 3512B HD with Electronic Injection and Multi Point Oil Pressure Sensing Fan Clutch Fast fill fuel system, Wiggins Ground level: Engine shutdown Battery Disconnect Lighting system: Back up lights, HID Direction signals and hazzard warning (rear halogen) Headlights, HID, with dimmer Ladder light and service decklights Stop and tail lights (LED) Engine Compartment Lighting Front to Rear wire-way tube	Tow hooks (front & rear), front tow pin Transmission: six speed, automatic power shift, electronic control, downshift inhibitor, neutral start switch, reverse shift inhibitor, controlled throttle shifting, directional shift management, neutral coast inhibitor, steep grade upshift inhibitor. Transmission Guard Vital Information Management System with Production Manager Special Tooling for Service Serviceability ladders at rear of truck Hydraulic actuated rear canopy

Optional Equipment

With approximate changes in weights.

Standard Equipment may vary. Consult Your Caterpillar Dealer for specifics.

	kg	lb		kg	lb
Auto Lube System w/60lb Reservoir	68	150	Heater, fuel recirculation type. non-electric	2	5
Visibility Cameras	45	100	Heater, engine coolant and oil 240-volt external power source	10	22
Payload Score Boards	91	200	Oil Renewal System	11.4	25
Load Lights	4.5	10	Prelube System	24	53
Inside Body Abuse Beam Protectors	635	1400	Traction Control System(TCS)	45	100
Top Abuse Beam Protectors	726	1600	Vandalism Protection Locks	4.5	10
Brake Release Motor for Towing	45	100	Oil Change System, Quick service for Engine & Transmission	See Your Local Dealer	
Fire Supression System	See Your Local Dealer		36 x 51-E3 Tires (Set of 8)	2947	6496

Kress has multiple truck body length configurations to maximize your productivity based on the density of your haulage material.

Corporate Offices and Factory
227 Illinois St • Brimfield Illinois, U.S.A 61517
Phone: (309) 446-3395 • FAX: (309) 446-9625
E-mail: sales@kresscarrier.com

www.kresscarrier.com

KRESS and **K** are registered trademarks of Kress Corporation.
Caterpillar and Cat are trademarks of Caterpillar Inc.

© 2003 Kress

Printed in U.S.A.

**Featured machines may include additional equipment only for special applications.
See your authorized Kress Dealer for available options.
Materials and specifications are subject to change without notice.**

Available From Your Local Caterpillar Dealer

